

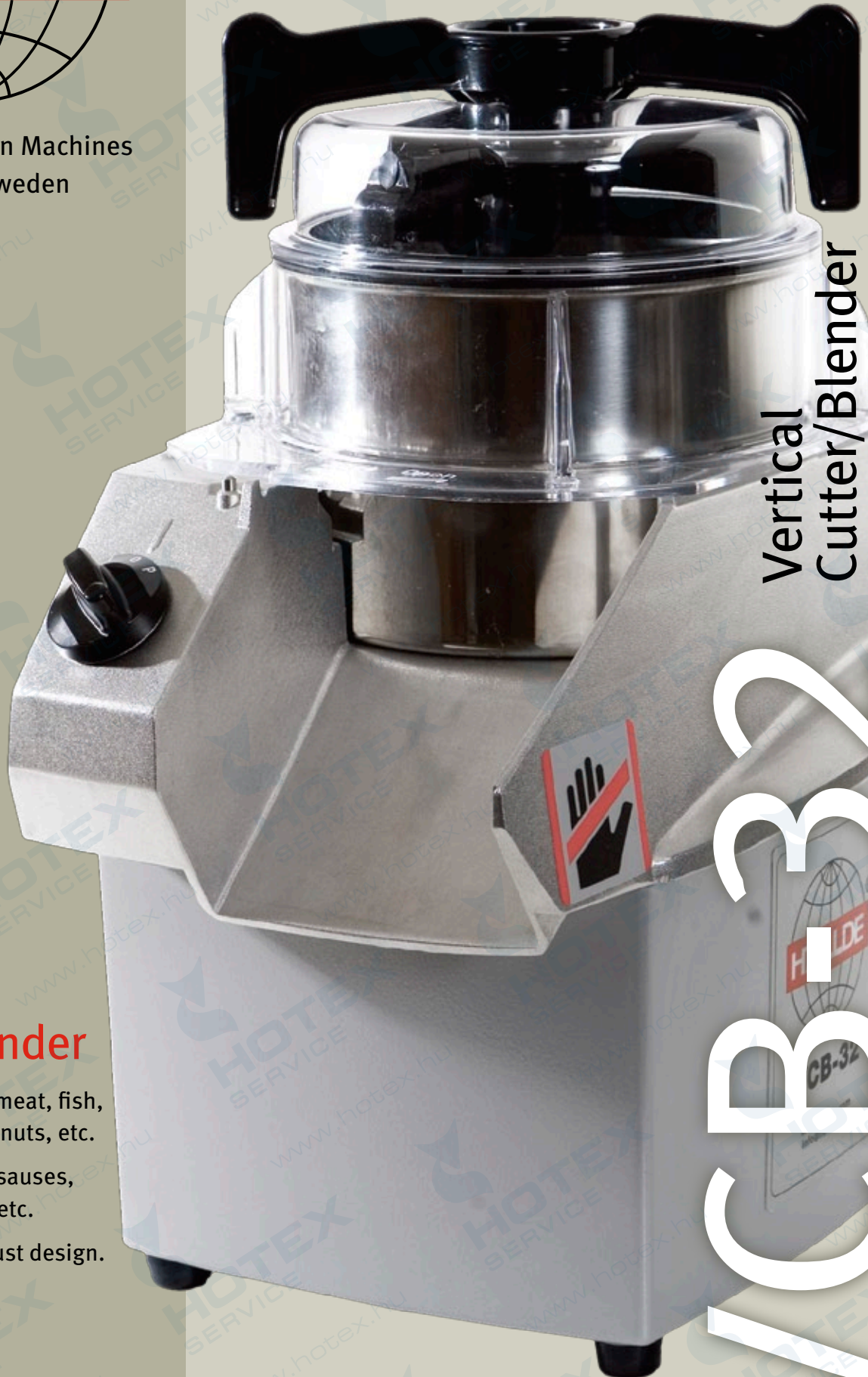

Food Preparation Machines
Made in Sweden



Vertical
Cutter/Blender

VCB-32 Vertical Cutter/Blender

- Chops and grinds meat, fish, vegetables, fruits, nuts, etc.
- Blends and mixes sauses, soups, dressings, etc.
- Table top with robust design.
- Volume 3 liter.

VCB-32

Small and versatile

HALLDE's VCB-32 is a versatile vertical cutter/blender for the smaller kitchen. It is small in size but has smart functions which always ensuring perfect and even results.

Larger volumes

The three litre bowl has a tightly sealing lid. This increases the net volume for liquid ingredients to 1.4 litres. The lid has a 3 cm wide feed tube for filling while the machine is running. The transparent lid makes it easy to monitor your cutting when using the machine.



Adapted speeds

You can run the VCB-32 at two speeds; 1,450 rpm for gentle preparation and better control when chopping, and 2,650 rpm for rapid mixing or blending of sauces or minced meats. The VCB-32 also has a direct action pulse function. The pulse function provides direct access to 2,650 rpm without any irritating time delays.

Patented scraper

The VCB-32 has a scraper system designed to prevent food getting stuck on the inside and the lid of the bowl, where the knives are unable to reach. The scraper arms keep the lid and the inside of the bowl clean. At the same time they move the ingredients back towards



Exemplary safety features

The VCB-32 has two individual safety switches. You can only start the machine if the bowl and lid have been correctly fitted.



Effective preparation

The knife unit in combination with the scraper system means very short preparation times and reduces temperature rises in the ingredients.



User friendly ergonomics

You control the machine using one knob instead of several buttons. The knob is located on the left hand side allowing your right hand to remain free for the scraper or for filling. The knob is at a convenient height to ensure an ergonomic working posture.



Lightweight and easy to move

The machine is small in size. It doesn't take up a lot of space in the kitchen and it is easy to move. Something which is helped by the generously sized handle on the side.

the knives. The VCB-32 scraper system has three arms instead of one. It is a patented function that means that the rotation of the ingredients in the bowl is stopped enabling the knives to cut the contents more effectively. This shortens preparation time considerably and minimises the heat release that arises when preparing.

Even results with minimal temperature rise

The design and angle of the knives in combination with the scrapers means that the ingredients are turned in the bowl giving the whole content a uniform texture. This gives perfect results in double quick time. The knives are serrated which makes them wear resistant.

Developed for best hygiene

The VCB-32 is manufactured solely from hygiene certified material. The machine has smooth surfaces, rounded edges and

has no unnecessary recesses where food might penetrate and get stuck. For rapid cleaning, all loose components are easy to remove making the machine easy to rinse. All loose parts can be washed in the dishwasher.

Only the best material

The machine base is manufactured of robust metal. The bowl is stainless steel, the lid is polycarbonate and the scrapers are strong polysulphone. The knife attachment is acetal and the knives are stainless steel.

Highest possible reliability

The powerful motor has a high torque and is geared down, which makes the VCB-32 an exceptionally reliable machine – irrespective of the foods you are working with. If the motor is called on to work harder, more power is supplied to ensure even running.



VCB-32 Results



Minced meat



Parsley



Chocolate



Dessert



Soup



Aromatic butter



Onion



Almond



Fish mousse



Dressing



Herb oil



Mayonnaise

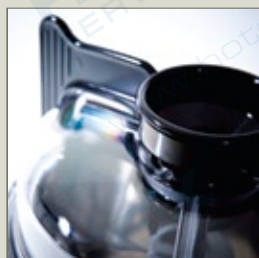
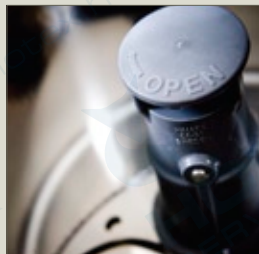

VCB-32 Vertical Cutter/Blender

- The machine base and bowl are made of metal and can withstand rough handling.
- The direct action pulse function produces 2,650 rpm without any delay.
- Two speeds, 1,450 rpm and 2,650 rpm.
- Patented scraper with three scraper arms that together with the design of the knife shortens preparation time and minimises temperature rises.
- Two safety switches make it impossible to start the machine if the knife is exposed.
- All loose parts can be washed in the dishwasher.
- The table top model is easy to put away and take out when needed with its two sturdy handles at the sides.

Machine

- Motor: 1000 W. Two speeds.
100-120 V, 1-phase, 50-60 Hz. 220-240 V, 1-phase, 50-60 Hz.
- Transmission: Maintenance free belt.
- Safety system: Two safety switches.
- Degree of protection machine: IP34.
- Power supply socket: Earthed, 1-phase, 10 A.
- Fuse: 10 A, delayed action fuse.
- Sound level LpA (EN31201): 82 dBA.
- Magnetic field: Less than 0,1 mikrotesla.

Materials

- Machine base: Aluminium.
- Bowl: Stainless steel.
- Lid: Polycarbonate.
- Scraper system: Polysulphone.
- Knife balk: Acetal.
- Knives: Stainless steel.

Volumes and dimensions

- Bowl volume: Gross 3 liter. Net liquids 1,4 liter.
- Feed tube diameter: 30 mm.

Knife unit

- Knife unit diameter: 180 mm.
- Speed: 1450 och 2650 rpm.

Type of preparation

- Chops, grinds, blends and mixes.
- Prepares dressings, herb oils, aromatic butters, thickenings, mayonnaise, sauces, soups, minced meats, purées, patées, etc.
- Prepares meat, fish, fruit, vegetable, nuts, cheese, mushroom, chocolate, etc.

Users

- Restaurants, shops, diet kitchens, salad bars, schools, day care centers, fast food kitchens, catering kitchens, etc.

Nettovikt

- Machine base: 8,8 kg.
- Bowl complete: 1,4 kg.

Standards

- EU Directive 98/37/EEC, LVD 73/23 EEC, EMC 89/336/EEC. • NSF/ANSI Standard 8.

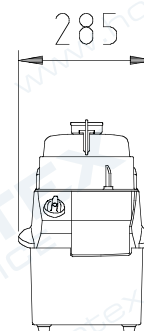
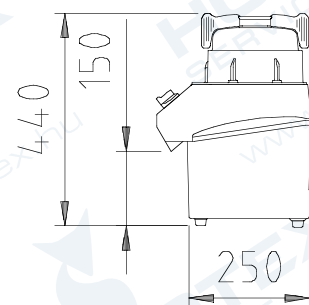

Food Preparation Machines
Made in Sweden



AB Hallde Maskiner P.O. Box 1165 SE-164 26 Kista Sweden
• Phone: +46 8 587 730 00 • Fax: +46 8 587 730 30 • www.hallde.com • info@hallde.com