



Food Preparation Machines
Made in Sweden

RG-100 Vegetable Preparation Machine

- Slices, dices, shreds, grates makes julienne and crimping slices.
- Processes fruit, vegetables, dry bread, cheese, nuts, mushrooms, etc.
- Table top machine made for commercial use and long life.
- High capacity. Processes up to 400 portions/day and 5 kg/minute.



Vegetable Preparation Machine

RG-100



Size that matters

RG-100 is designed to suit the kitchen with smaller volumes but who needs the quality and power of a large professional vegetable preparation machine. The size makes the machine suitable to use directly on a kitchen workbench. The leaning design means that the feed cylinder is always positioned at the right angle making it is easy to top up.

Safe and quick top ups

Thanks to the automatic start and stop function the machine stops as soon as the pusher plate is swung aside. When it is swung back the machine restarts and you can continue working. A clear advantage, particularly when larger volumes are involved.

Double safety against unprotected blades

If the feed cylinder is removed the power is cut. Thanks to this double security there is no risk of the machine starting with an unprotected blade.

Developed for the best hygiene

The RG-100 is manufactured solely from hygiene certified material. The machine has smooth surfaces, rounded edges and has no unnecessary recesses where food might penetrate and get stuck.

Easy cleaning

For quick cleaning are all loose parts simple to remove for easy rinsing of the machine. The feed cylinder is removable and can be cleaned under running water.

Only the best material

Machine base, feed cylinder and pusher plate are all made of robust metal. Only top quality stainless steel is used to manufacture the cutting tool knife blades.

Lightweight and easy to move

The relatively small size of the machine gives several advantages. It does not take up a lot of space in the kitchen. You can use it as a table top machine. And it is easy to move, something which is helped by the generously sized handle on the back.



Highest possible reliability

The powerful motor has a high starting and running torque and powers the direct-driven cutting tool. No belts or intermediate connections. The power from the motor goes via a maintenance free gear drive. This makes the RG-100 an exceptionally reliable machine – irrespective of the products you are preparing.

Cutting tools with complete register

Our wide range of cutting tools means the RG-100 can handle every conceivable task. You choose the cutting tool you need to make you even more efficient in the kitchen. The RG-100 slices, dices, shreds, grates, makes juliennes and crimping slices – everything from firm to soft products. The blades and grating plates are replaceable. As a result you do not need to buy new cutting tools.



Always perfect cutting results

The rotation speed of the cutting tools is optimised for cutting fine and even slices as efficiently as possible. The blades are purposely sharpened to avoid inertia or the edge breaking off.



RG-100 Accessories



Machine Table



Container Trolley



Knife Guard



Pipe Insert for thin vegetables



Angle Cut Feed Head



Wall Rack



Brush

Top quality cutting tools for any cut and optimal results



Standard Slicer

8, 10 mm.

- Slices firm products such as root vegetables.

- Dices in combination with a suitable dicing grid.



Fine Cut Slicer

1, 1.5, 2, 3, 4, 5,
6, 7-9, 10, 15 mm.

- Slices firm and soft products, such as root vegetables, bell pepper, onion, leek, cucumber, tomato, apple, citrus fruit, bananas, mushrooms, etc.

- Shreds lettuce and cabbage.
- Chops onions in combination with dicing grid.
- Dices in combination with suitable dicing grid.



Crimping Slicer

4-5 mm.

- For ripple slicing of beetroot, cucumber, carrots, etc.



Dicing Cutter

12-5 mm.

- Dices root vegetables, potatoes, cabbage in combination with dicing grid.



Julienne Cutter

2X2, 2.5X2.5, 4.5X4.5,
6X6, 8X8, 10X10 mm.

- Makes julienne potatoes and carrots for soups, cucumber for salads, etc.

- Julienne potatoes to curved French fries.

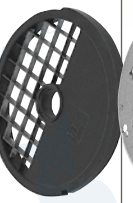

Dicing Grid

6.25X6.25, 7.5X7.5, 10X10,
12.5X12.5, 15X15, 20X20 mm.

- Dices root vegetables, fruit, potatoes, cabbage, swedes, carrots, cucumbers, apples, etc. in combination with a suitable standard slicer or fine cut slicer.

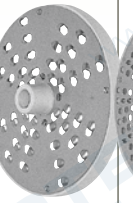

Grater/Shredder

1.5, 2, 3, 4-5, 6, 8, 10 mm.

- Grates carrots and cabbage for raw salad.
- Grates nut, almonds and dry bread.

- Grates cheese for pizza and gratin.
- Shreds cabbage/white cabbage.



Fine Grater Extra Fine Grater Hard Cheese Grater

- Grates root vegetables, dry bread, cheese etc.
- Fine Grater grates raw potatoes for potato pancakes.

- Extra Fine Grater grates radish, dry bread, etc.
- Hard Cheese Grater is perfect for cheese such as parmesan.



Soft Dicing

8, 10, 12, 15 mm.

- Combination to dice soft products like tomatoes, onion, pepper, bananas, kiwi, strawberries etc.



RG-100 Vegetable Preparation Machine

- Large half moon shaped feed cylinder that can take most items whole.
- Direct driven cutting tools from a strong heavy duty motor with planetary gear transmission.
- Leaning design reduces stress on shoulders and back when the machine is being refilled.
- Angle top Feed head as an accessory for cutting angle shaped slices. Good for Asian wok dishes or for different types of soup.
- Easy piling of tomatoes, onions, bell peppers etc. for oriented slicing.
- Table top model that can be used on a kitchen workbench.

Machine

- Motor: 0.25 kW. One-speed. 100 V, single phase, 50-60 Hz. 110-120 V, single phase, 60 Hz. 220 V, single phase, 50 Hz. 230-240 V, single phase, 50 Hz. 230 V, three phase, 50 Hz. 400 V, three phase, 50 Hz. 440 V, three phase, 60 Hz.
- Transmission: Planetary gearing.
- Safety system: Two safety switches.
- Degree of protection machine: IP44.
- Degree of protection push buttons: IP65.
- Power supply socket: Earthed, single phase, 10 A.
- Fuse: 10 A, delayed action fuse.
- Sound level LpA (EN31201): 70 dBA.
- Magnetic field: Less than 0.5 microtesla.

Materials

- Machine housing: Anodized and polished aluminium alloy.
- Cutting tool discs: Aluminium alloy.
- Cutting tool knife blades: Stainless knife steel.
- Machine table: Stainless steel.
- Container: Polycarbonate.

Feeder

- Feed cylinder: Volume 1.65 litre. Height 150 mm. Diameter 170 mm.
- Feed tube with internal diameter 56 mm.

Cutting tools

- Diameter: 185 mm.
- Speed: 350 rpm (50 Hz), 420 rpm (60 Hz).

Type of preparation

- Slices, dices, shreds, grates, makes julienne and crimping slices.
- Processes fruit, vegetables, dry bread, cheese, nuts, mushrooms, etc.

Users

- For restaurants, pizzerias, salad bars, schools, hospitals, fast food counters, ships, catering kitchens, etc.

Net weights

- Machine: 16 kg.
- Cutting plates: 0.5 kg.

Standards

- EU Directive 98/37/EEC, LVD 73/23 EEC, EMC 89/336/EEC. • NSF/ANSI Standard 8.

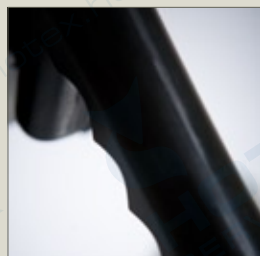
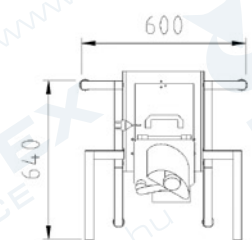
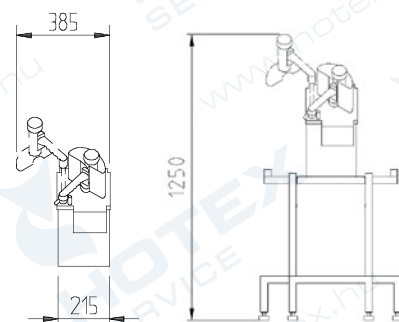
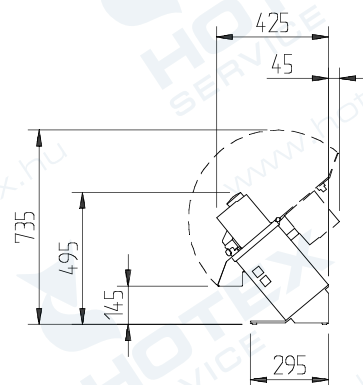

Food Preparation Machines
Made in Sweden



AB Hallde Maskiner P.O. Box 1165 SE-164 26 Kista Sweden
• Phone: +46 8 587 730 00 • Fax: +46 8 587 730 30 • www.hallde.com • info@hallde.com