

# Waste Disposers

Kitchen hygiene with style and functionality

## IMC Food Waste Disposers

### Peace Of Mind Guaranteed

IMC is the major European manufacturer of specialised catering and bar equipment and the leading supplier of commercial food waste disposers.

Our products are used throughout the catering sector – from street corner cafés to world-class restaurants, and from schools and prisons, to hospitals and nursing homes.

We are renowned for quality, reliability and innovation, with an unrivalled reputation for customer service and support that gives you total peace of mind every time you choose an IMC product.



### Performance and Reliability

IMC food waste disposers are built to ensure a long operating life, with each unit being constructed from hygienic stainless steel to withstand continuous use in the most demanding of applications.

IMC food waste disposers are compact and efficient, combining safety and ease of use with performance, functionality and reliability. In addition, our wide range of products and options enable each unit to be specified to meet your exact requirements.

Features include operator safety interlocks, automatic water controls, low-load cut-outs for energy and water efficiency, as well as reversible motors that extend operating life still further.



**For information on how to select the best system please refer to the fold out section.**



### **Fast Payback**

IMC food waste disposers allow you quickly and simply to remove waste as it is produced, enabling you to meet best hygiene practices and create a cleaner and safer working environment.

Our food waste disposers will also help you combat the steadily rising costs of waste handling, storage and disposal, while improving the use of staff time, eliminating unpleasant odours, spillages and the risk of contaminating fresh or cooked food.

With high capacity, a long trouble-free operating life and low capital and maintenance costs, our food waste disposers give you a fast payback on your investment.

### **Choice and Flexibility**

Our extensive range of food waste disposers means that whatever the size of your catering establishment we can provide a solution that offers superb choice and flexibility.

Our range of units can handle from as little as 100 to over 1,850 covers per sitting, with the option of customised units for special applications.

Each IMC food waste disposer is simple to install and maintain, and can easily be built into existing workflow patterns. Units can be free standing, fitted under sinks, mounted in tabling, or be integrated into dishwashers and cleaning areas; they can also be connected directly to Mechline systems.



## How IMC Food Waste Disposers Work

The IMC range of hygienic, stainless steel food waste disposers combine the latest product design with proven technology. This creates reliable, long-life units with the style and functionality to complement your modern kitchen systems. All IMC food waste disposers are CE marked.

### Quick and safe

Food preparation and table waste is fed into the hopper and ground into fine pieces. These are automatically washed into the drainage system in a single, quick and safe operation.

### System protection

The IMC automatic overload system protects the motor from damage if the grinder becomes jammed.

### Reversible motors

The direction of motor rotation can be reversed to minimise operational wear.

### Cutlery saver

Magnetic cutlery saver or cutlery saver baffle prevents damage to cutlery and the grinding unit.

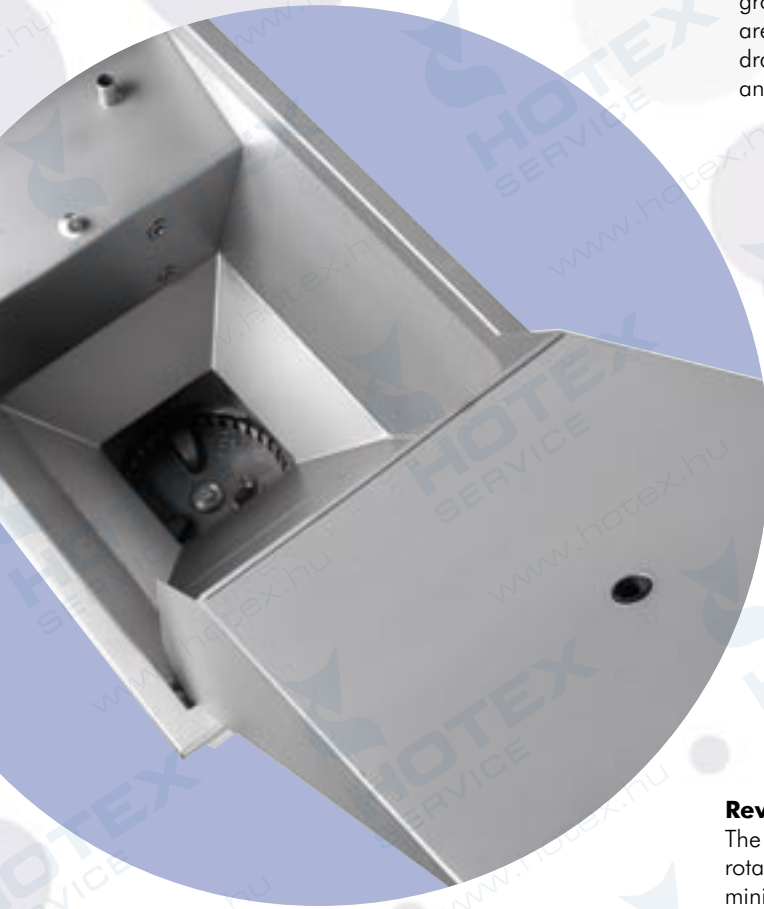

### Simple controls

Simple to use, waterproof IP65 controls can be integral, wall mounted or remote.

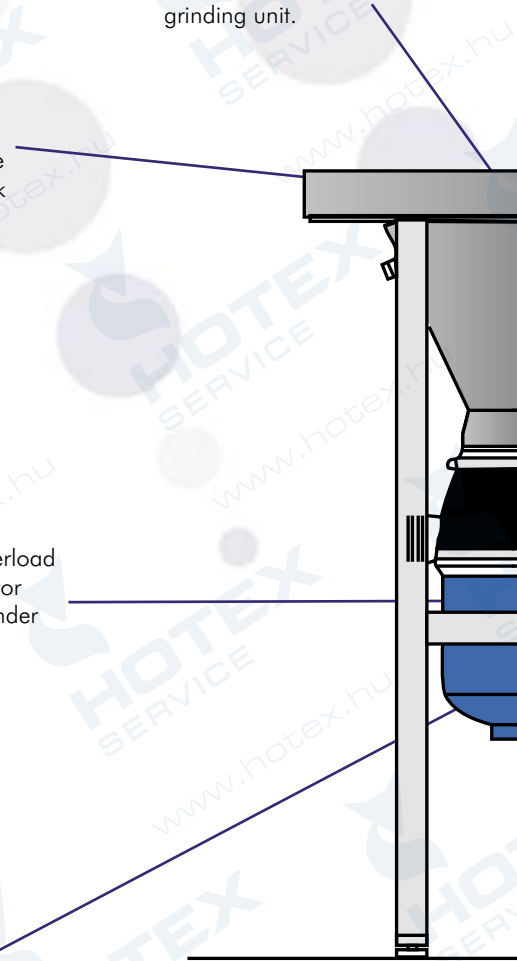



### Operator safety

The feed hopper is protected by a metal baffle and time delayed interlock system, to prevent access to the grinding unit while the machine is operating.



### Long life

Grinding elements are manufactured from specially case hardened steel alloys, for long operating life and resistance to damage, even with heavy use or where large bones are being ground.



### Reduce costs

Automatic water controls minimise water consumption and ensure that flow accurately matches machine demands.



### WRAS Approval

IMC 700, 800 and 04 Series food waste disposers that are plumbed directly into the mains water supply can also be supplied with Class A airbreaks.

The Class A airbreak eliminates any risk of contamination of a potable water supply and ensures that food waste disposers comply with WRAS regulations.

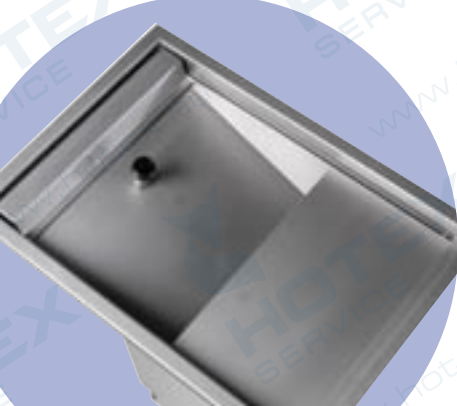

## 500 Series

### 500 Series: Ideal Solution For Small Catering Establishments

The compact 500 Series food waste disposers provide excellent value for small to medium size kitchens in pubs, bars, fast food outlets, cafés, restaurants, hospital wards and nursing homes, handling up to 400 covers per sitting.

The range can be mounted under sinks, integrated into tabling or be used as free-standing units. In each case, reliable, long-life motors, combined with special alloy grinding elements, enable a variety of soft food waste, including plate scrapings and vegetable peelings to be disposed of quickly and safely.

The 500 Series incorporates rubber housings, for quiet, efficient operation, safety petals in the under-sink unit and a baffle and interlock system in each hopper for complete safety.



523

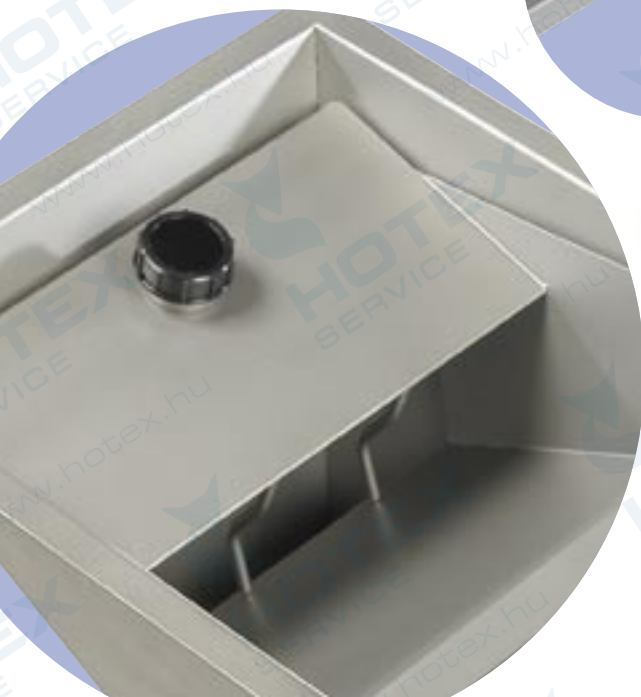
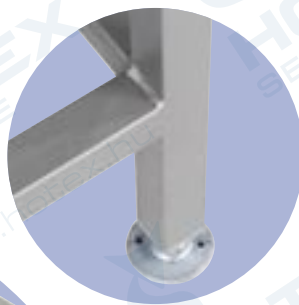

### 523

Mounting	Sink outlet
Capacity	200 covers per sitting 100kg of waste per hour
Motor	0.55kW (0.75HP)
Fuse rating	1 phase (16A) or 3 phase (6A)
Operator controls	IP65 rated waterproof wall mounted control box*
Water control	Manual with sink taps
Operator safety	Rubber petals at sink opening
Features	Rubber housing to minimise noise Automatic thermal overload to protect the motor Manually reversible motor for extended operational life Supplied with fitting for 89mm (3.5") sink opening

\* Motor on buttons (clockwise and anticlockwise) and off buttons



526

525

**525**

Mounting	Weld into tabling
Capacity	400 covers per sitting 200kg of waste per hour
Motor	0.55 kW (0.75HP)
Fuse rating	1 phase (16A) or 3 phase (6A)
Operator controls	IP65 rated waterproof wall mounted control box*
Water control	Automatic water control
Operator safety	Metal baffle and time delayed interlock system
Features	Rubber housing to minimise noise Automatic thermal overload to protect the motor Manually reversible motor for extended operational life

\* Motor on buttons (clockwise and anticlockwise) and off buttons

**526**

Mounting	Free standing
Capacity	400 covers per sitting 200kg of waste per hour
Motor	0.55kW (0.75HP)
Fuse rating	1 phase (16A) or 3 phase (6A)
Operator controls	IP65 rated waterproof integral controls*
Water control	Automatic water control
Operator safety	Metal baffle and time delayed interlock system
Features	Rubber housing to minimise noise Automatic thermal overload to protect the motor Manually reversible motor for extended operational life
Options	Stainless steel side panels

\* Motor on buttons (clockwise and anticlockwise) and off buttons



700 & 800 Series

**700 Series: Excellent Performance at Low Cost**

Compact and space saving 700 Series food waste disposers offer excellent throughput and performance at low operating cost.

The 700 Series food waste disposers can handle up to 850 covers per sitting, making them ideal for kitchens in medium sized hotels, restaurants, schools and hospitals.

Each 700 Series unit is fitted with a reliable, energy efficient 1.1kW, (1.5HP) motor, capable of grinding small chicken and pork bones, plate waste, vegetables, fruit and peelings.

Units can be free standing, mounted under sinks, or integrated into food preparation or dishwashing areas.



723



725 & 825

**723**

Mounting	Sink outlet
Capacity	400 covers per sitting 200kg of waste per hour
Motor	1.1kW (1.5HP)
Fuse rating	1 phase (16A) or 3 phase (6A)
Operator controls	IP65 rated waterproof wall mounted control box*
Water control	Automatic water control
Operator safety	Metal baffle
Features	Automatic thermal overload to protect the motor Manually reversible motor for extended life. Supplied with fittings for welding into sink opening

\* Motor on buttons (clockwise and anticlockwise) and off buttons

**725 & 825**

Mounting	Weld into tabling
Capacity	<b>725</b> 850 covers per sitting 400kg of waste per hour <b>825</b> 1350 covers per sitting 600kg of waste per hour
Motor	<b>725</b> 1.1kW (1.5HP) <b>825</b> 2.2kW (3.0HP)
Fuse rating	<b>725</b> 1 phase (16A) or 3 phase (6A) <b>825</b> 3 phase (10A)
Operator controls	IP65 rated waterproof wall mounted control box*
Water control	Automatic water control
Operator safety	Metal baffle and time delayed interlock system
Features	Automatic thermal overload to protect motor Manually reversible motor for extended life
Options	Class A airbreak Magnetic cutlery saver

\* Motor on buttons (clockwise and anticlockwise) and off buttons



Each unit features tough, hardened steel alloy cutting elements, and offers a high degree of operator safety, with standard baffle and interlock systems preventing access to the grinding unit while motors are running.

### 800 Series: Optimum High Volume Performance

800 Series food waste disposers provide higher capacity waste disposal for up to 1350 covers per sitting in larger hotels, hospitals, universities and prisons, plus food preparation companies.

Each unit is powered by a high performance 2.2kW (3.0HP) motor, enabling you to dispose safely of tough waste materials such as large red meat bones, cauliflower stalks and fish skins.

800 Series units can be free-standing, mounted under sinks, or fitted into food preparation or dishwashing areas. Each unit has long life, hardened alloy cutting elements and offers a high degree of operator safety, with standard baffle and interlock systems to prevent access to the grinding unit while the motor is running.

A special 825DS unit incorporating a large self-contained feed table and a retractable pre-rinse spray, to help rinse pots and clean the waste disposer, is also available.

**The 700 & 800 Series are available with Class A airbreaks**



726 & 826



825DS

#### 726 & 826

Mounting	Free standing
Capacity	<b>726</b> 850 covers per sitting 400kg of waste per hour <b>826</b> 1350 covers per sitting 600kg of waste per hour
Motor	<b>726</b> 1.1kW (1.5HP) <b>826</b> 2.2kW (3.0HP)
Fuse rating	<b>726</b> 1 phase (16A) or 3 phase (6A) <b>826</b> 3 phase (10A)
Operator controls	IP65 rated waterproof integral controls*
Water control	Automatic water control
Operator safety	Metal baffle and time delayed interlock system.
Features	Automatic thermal overload to protect motor Manually reversible motor for extended life
Options	Stainless steel side panels Class A airbreak Magnetic cutlery saver Remote control box (826 model only)

\* Motor on buttons (clockwise and anticlockwise) and off buttons

#### 825DS

Mounting	Free standing
Capacity	1450 covers per sitting 700kgs of waste per hour
Motor	2.2kW (3.0HP)
Fuse rating	3 phase (10A)
Operator controls	IP65 rated waterproof integral controls*
Water control	Automatic water control
Operator safety	Metal baffle and time delayed interlock system
Features	Retractable pre-rinse spray for dishes and cleaning Large self contained tabling with high edges for better waste containment Automatic thermal overload to protect the motor Manually reversible motor for extended life
Options	Stainless steel side panels Class A airbreak Magnetic cutlery saver Remote control box

\* Motor on buttons (clockwise and anticlockwise) and off buttons

For more information see technical specification leaflet  
Marine voltages available



## 04 & 04X Series

### 04 Series: The Ultimate Heavy Duty System

The 04 Series food waste disposers provide the ultimate heavy duty solution for processing higher volumes of food waste in kitchens handling from 1000 up to 1850 covers per sitting. Designed for use in large hotels and restaurants, hospitals, prisons, universities and by food preparation companies, the 04 Series can handle difficult waste including fish skins, cauliflower stalks and larger meat bones.

Fitted with a choice of high performance motors, to ensure fast, reliable and energy efficient grinding of waste, the 04 Series can be used as a free standing unit, integrated into tabling or installed using a special hopper ring for even simpler installation and servicing.

04 units feature steel alloy grinding elements, safety baffles and interlock systems, plus auto-reverse motors, to ensure consistent wear and extend operating life.

04 food waste disposers can also be supplied with a single or double entry trough unit to allow waste to be fed simultaneously from several workstations and improve kitchen productivity still further.

The 04X Series food waste disposers incorporate all the features of the 04 Series, plus additional 12V control systems to monitor and control operating conditions. These provide alarm indicators to optimise water and power consumption, and to protect against damage and misuse. The 04X Series also offers automatic self-cleaning functions.

pictured: hopper version



904/904X

### 904/904X

Mounting	Free standing, welded into tabling or sit into hopper rim welded into tabling
Capacity	1000 covers per sitting 500kg of waste per hour
Motor	1.1kW (1.5HP)
Fuse rating	1 phase (16A) or 3 phase (6A)
Operator controls	IP65 rated waterproof integral on/off controls buttons*
Water control	Automatic water control
Operator safety	Metal baffle and time delayed interlock system
Features	<p><b>904</b> Automatic thermal overload to protect motor. Automatically reversible motor for extended life Adjustable machine height</p> <p><b>04 trough model</b> IP65 rated waterproof wall mounted control box Manually reversible motor for extended life Adjustable machine height</p> <p><b>904X</b> Automatic electronic overload to protect motor Automatically reversible motor for extended life. Machine status indicator and alarm Motor seal failure indicator, alarm and immobiliser Low-load cut-out for energy and water efficiency Automatic self-cleaning system Adjustable machine height</p>
Options	<p><b>04 and 04X</b> Class A airbreak Magnetic cutlery saver Cutlery saver baffle Hopper rim for sitting in tabling for ease of service Remote control box</p> <p><b>04 trough model</b> Double trough (DT) or single trough (ST) Magnetic cutlery saver</p>

\* Trough unit uses wall mounted control box



pictured: single trough version (04 model only)



1204/1204X

pictured: double trough version (04 model only)

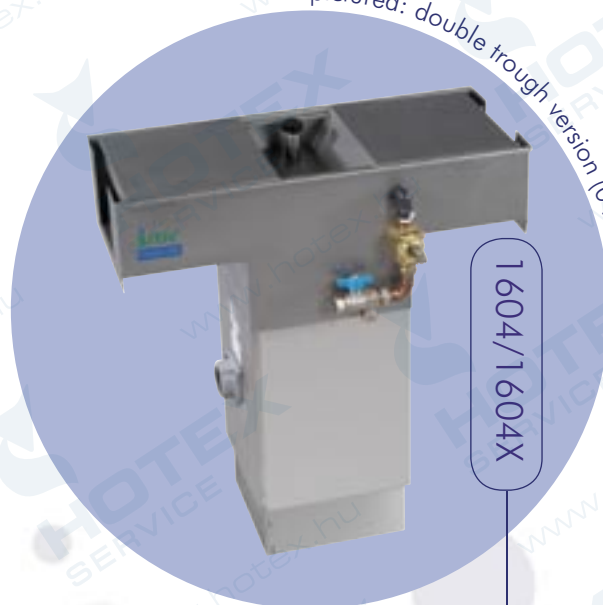

1604/1604X

#### 1204/1204X

Mounting	Free standing, welded into tabling or sit into hopper rim welded into tabling
Capacity	1450 covers per sitting 700kg of waste per hour
Motor	2.2kW (3.0HP)
Fuse rating	3 Phase (10A)
Operator controls	IP65 rated waterproof integral on/off controls buttons*
Water control	Automatic water control
Operator safety	Metal baffle and time delayed interlock system
Features	<p><b>1204</b> Automatic thermal overload to protect motor. Automatically reversible motor for extended life Adjustable machine height</p> <p><b>04 trough model</b> IP65 rated waterproof wall mounted control box Manually reversible motor for extended life Adjustable machine height</p> <p><b>1204X</b> Automatic electronic overload to protect motor Automatically reversible motor for extended life. Machine status indicator and alarm Motor seal failure indicator, alarm and immobiliser Low-load cut-out for energy and water efficiency Automatic self-cleaning system Adjustable machine height</p>
Options	<p><b>04 and 04X</b> Class A airbreak Magnetic cutlery saver Cutlery saver baffle Hopper rim for sitting in tabling for ease of service Remote control box</p> <p><b>04 trough model</b> Double trough (DT) or single trough (ST) Magnetic cutlery saver</p>

\* Trough unit uses wall mounted control box

#### 1604/1604X

Mounting	Free standing, welded into tabling or sit into hopper rim welded into tabling
Capacity	1850 covers per sitting 900kg of waste per hour
Motor	4.0kW (5.5HP)
Fuse rating	3 phase (16A)
Operator controls	IP65 rated waterproof integral on/off controls buttons*
Water control	Automatic water control
Operator safety	Metal baffle and time delayed interlock system
Features	<p><b>1604</b> Automatic thermal overload to protect motor Automatically reversible motor for extended life Adjustable machine height</p> <p><b>04 trough model</b> IP65 rated waterproof wall mounted control box Manually reversible motor for extended life Adjustable machine height</p> <p><b>1604X</b> Automatic electronic overload to protect motor Automatically reversible motor for extended life Machine status indicator and alarm Motor seal failure indicator, alarm and immobiliser Low-load cut-out for energy and water efficiency Automatic self-cleaning system Adjustable machine height</p>
Options	<p><b>04 and 04X</b> Class A airbreak Magnetic cutlery saver Cutlery saver baffle Hopper rim for sitting in tabling for ease of service Remote control box</p> <p><b>04 trough model</b> Double trough (DT) or single trough (ST) Magnetic cutlery saver</p>

\* Trough unit uses wall mounted control box

## Product Dimensions

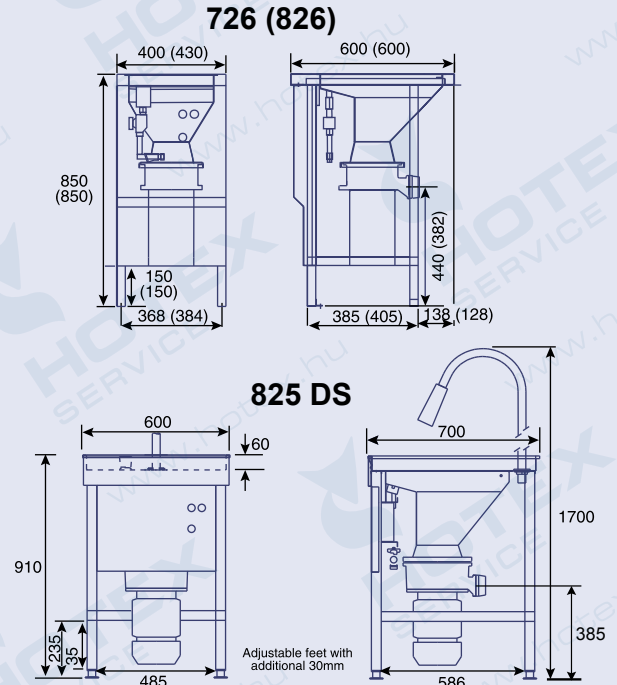
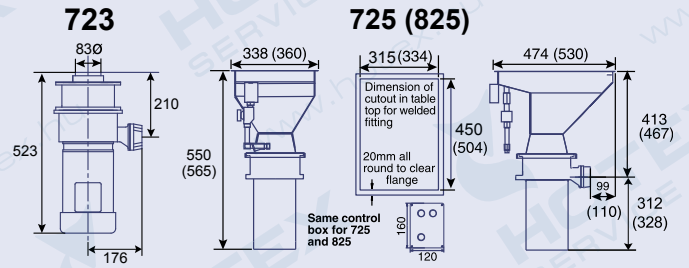
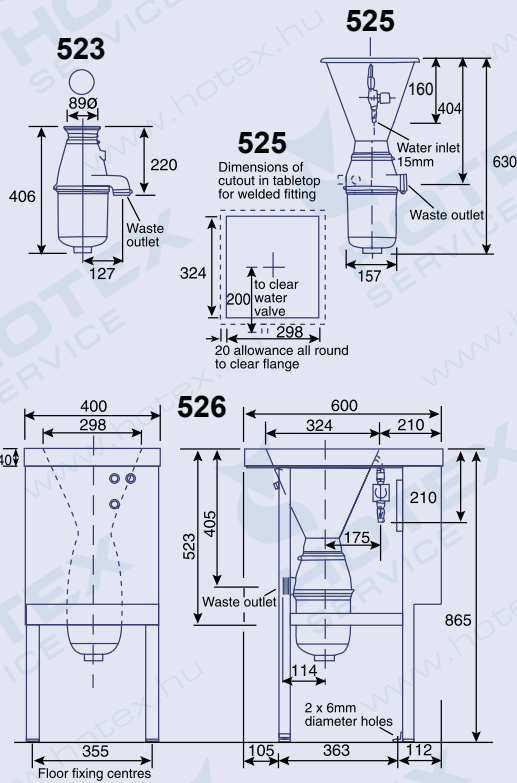

## 04 Series

### Optional remote button box

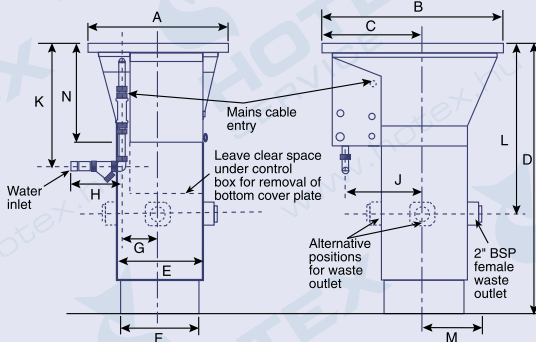
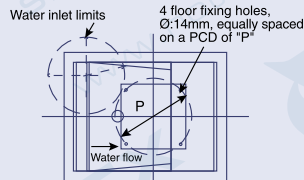
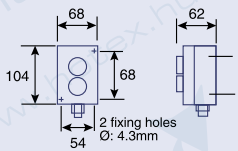

### Dimensions of cut-out in tabling

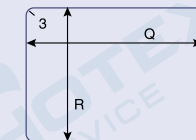

The waste disposer hopper can be welded directly to the cut-out in the tabling, or sealed to a special hopper rim which is itself welded to the cut-out (see dimensions below).

### Dimensions of hopper rim

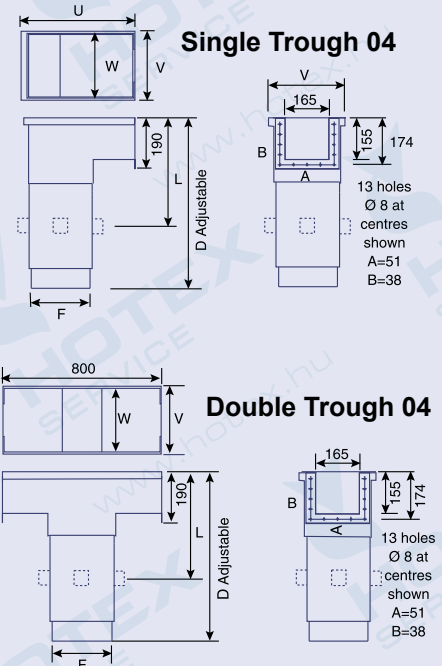
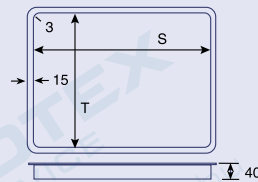

Model	DMin	DMax	F	L	U	V	W
904ST & 904DT	800	905	252	508	551	302	276
1204ST & 1204 DT	850	900	298	498	574	349	323
1604ST & 1604DT	850	900	298	498	574	349	323

Model	A	B	C	DMin	DMax	E	F	G	H	J	K	L	M	N	P	Q	R	S	T
904(X)	438	564	321	800	905	275	252	110	105	252	396	508	178	295	298	510	385	494	368
1204(X) & 1604(X)	514	740	361	850	900	322	298	125	138	283	410	499	202	310	362	685	460	672	444

## How To Select The Best System

To help you select the best system for your application, please use the chart below by comparing the covers per sitting with the type of waste you wish to dispose of. The chart also shows which units are compatible with dewaterers and trough systems.

Covers per sitting	200	400	400	400	850	850	1000	1000	1350	1350	1450	1450	1450	1850	1850
Waste/hour (kg)	100	200	200	250	400	400	500	500	600	600	700	700	700	900	900
<b>Soft waste:</b> plate waste, vegetables & peelings, meat & fish scraps	✓	✓	✓	✓	✓	✓	✓	✓	✓	✓	✓	✓	✓	✓	✓
<b>Medium waste:</b> small pork & chicken bones, vegetables & fruit				✓	✓	✓	✓	✓	✓	✓	✓	✓	✓	✓	✓
<b>Tough waste:</b> red meat bones, cauliflower stalks & fish skins									✓	✓	✓	✓	✓	✓	✓
<b>Compatible with WastePro</b>				✓	✓	✓	✓		✓	✓	✓	✓		✓	
<b>Compatible with Troughs</b>							✓	✓				✓	✓	✓	✓
Model N°	523	525	526	723	725	726	904	904X	825	826	825DS	1204	1204X	1604	1604X
Page Number	5	6	6	7	7	8	9	9	7	8	8	10	10	10	10

Please Note: All capacities are approximate and may vary depending on the mix of waste types.





Also available is our range of Compactors, WastePro food waste dewaterers and combined SYS2000 food waste disposer and dewaterer. Designed for use where food waste cannot be disposed of via mains drainage, these systems can reduce waste volumes by up to 80% and are capable of handling up to 150kg of waste per hour. Please contact us for further details.



IMC was founded in 1906 and has since established itself as a leading manufacturer of catering and bar equipment, with a reputation for quality, innovation and unrivalled customer service.



We have the resources, manufacturing expertise, knowledge and skills to provide you with complete waste management and catering solutions and to offer custom built equipment, all of which is designed and manufactured in an ISO9001 approved environment.

**Imperial Machine Company Limited**

Unit 1 Abbey Road  
Wrexham Industrial Estate  
Wrexham  
LL13 9RF  
United Kingdom

Tel: +44 (0)1978 661155  
Fax: +44 (0)1978 729990  
Email: fwd@imco.co.uk  
www.imc-fwd.co.uk

