

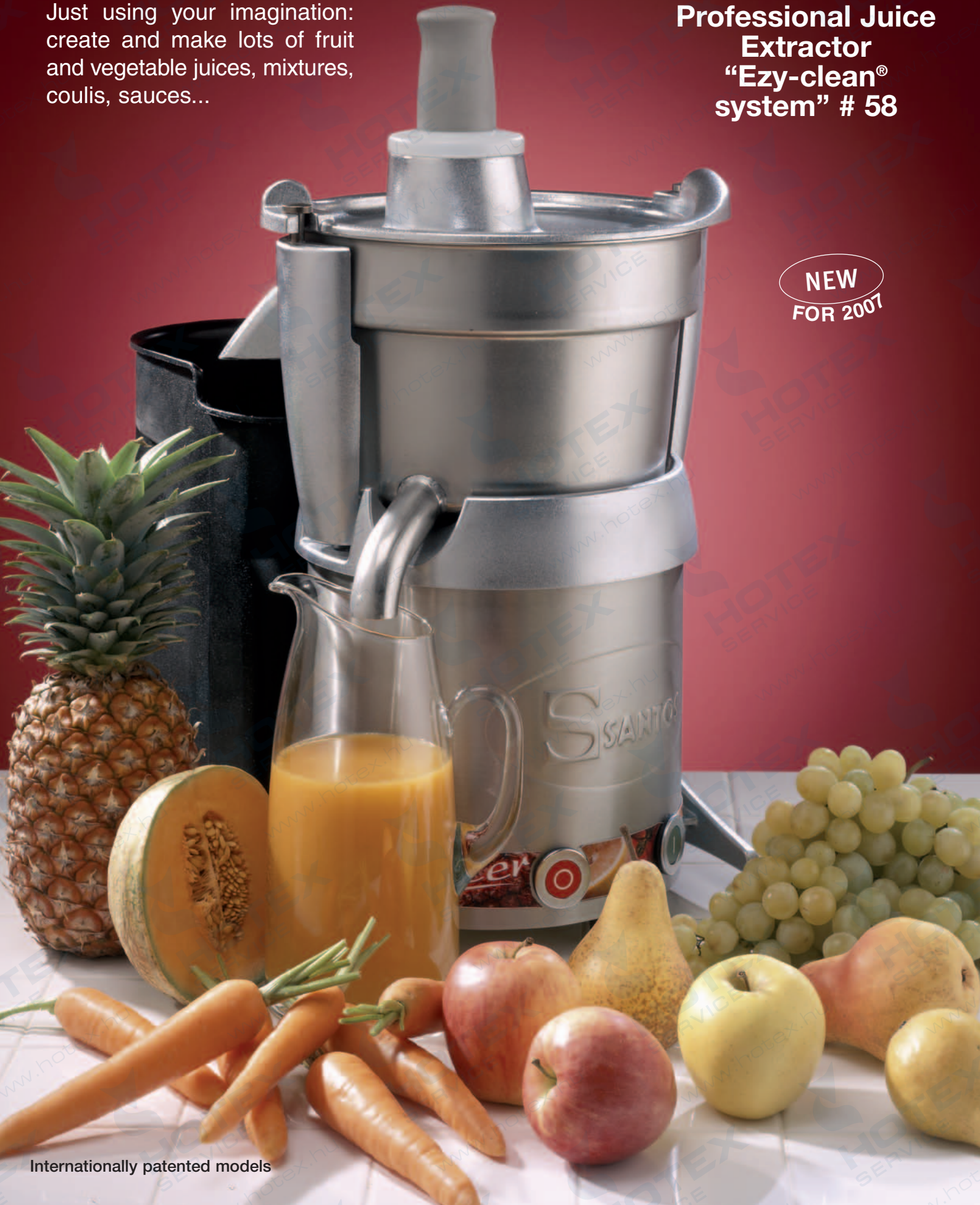

Just using your imagination:
create and make lots of fruit
and vegetable juices, mixtures,
coulis, sauces...

Professional Juice Extractor “Ezy-clean® system” # 58

NEW
FOR 2007



Internationally patented models



Professional Centrifugal Juice

Introducing the Santos Juicer #58



SAFETY - STANDARDS - HYGIENE

In accordance with the following regulations:

- Machinery directive 98/37CE
- Electromagnetic compatibility 89/336/CEE
- Electrical equipment designed for use within certain voltage limits "low voltage" 73/23/ECC
- Harmonized European standards: EN 292-1 and 2 – EN 60204-1 : 1998

Hygiene:

All removable parts can be put in a dishwasher or easily cleaned with hot soapy water.

Thermal safety:

Motor protected by internal thermal detector and overload protector.

TECHNICAL DATA

Technical specifications:

- **Motor :**
 - Power 800 W
 - Single phase: 100-120 V – 50/60 Hz – **UL & NSF (pending)**
 - 220-240 V – 50/60 Hz – **CE GS & Keti (pending)**
 - Speed: 3000 RPM (50Hz)
3600 RPM (60 HZ)
- **Weight:**
 - Net: 24 Kg (53 lbs)
 - Shipping: 27 Kg (59,5 lbs)

Extractor "Ezy-clean® system" #58

www.santos.fr

Santos: worldwide leader in commercial juicers



- 1955: First household centrifugal Juicer.
- 1986: Santos Juicer #28. First NSF, UL and GS approved juicer on the market. Worldwide used in kitchens, juice bars, hotels...
- 2000: Santos Juicer #50. First small, easy to clean commercial juicer dedicated to the Worldwide juice bar market. Ezy-clean® system launch
- 2006: Santos Juicer #58. The result of 40 years worldwide experience. Powerful and easy to clean commercial juicer.

Exclusive "Ezy-clean® system": easiness, efficiency & quality



No tool needed



Easy to clean



Save time

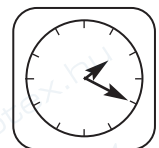

+

=

The professional centrifugal juice extractor #58 can produce pure juice with vitamins from most fruits and vegetables.

Save time and labour: no need to cut food into small pieces before juicing :

- Apples, carrots, tomatoes, cucumbers, celery, cabbage, onions, beets, pears, spinach...
- Citrus fruits : oranges, grapefruits, lemons and limes (must be peeled)
- Melons, pineapples, mangoes, kiwis, bananas (shall be peeled)
- Peaches, apricots, plums, tropical fruits (must be pitted)
- Berries: strawberries, raspberries, blackberries, blueberries...

It produces more than **one litre** of juice **per minute**.

It allows you to make all fruits and vegetable juice, cocktails, fruit sauce, coulis sauce, ice cream, sorbets...

Shipping box:

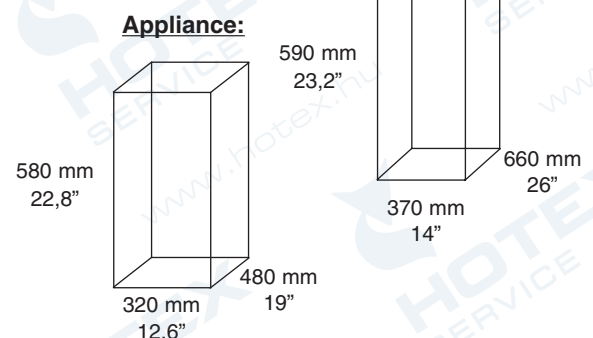

Professional centrifugal juice extractor Ezy-clean® system #58

