

# im|92

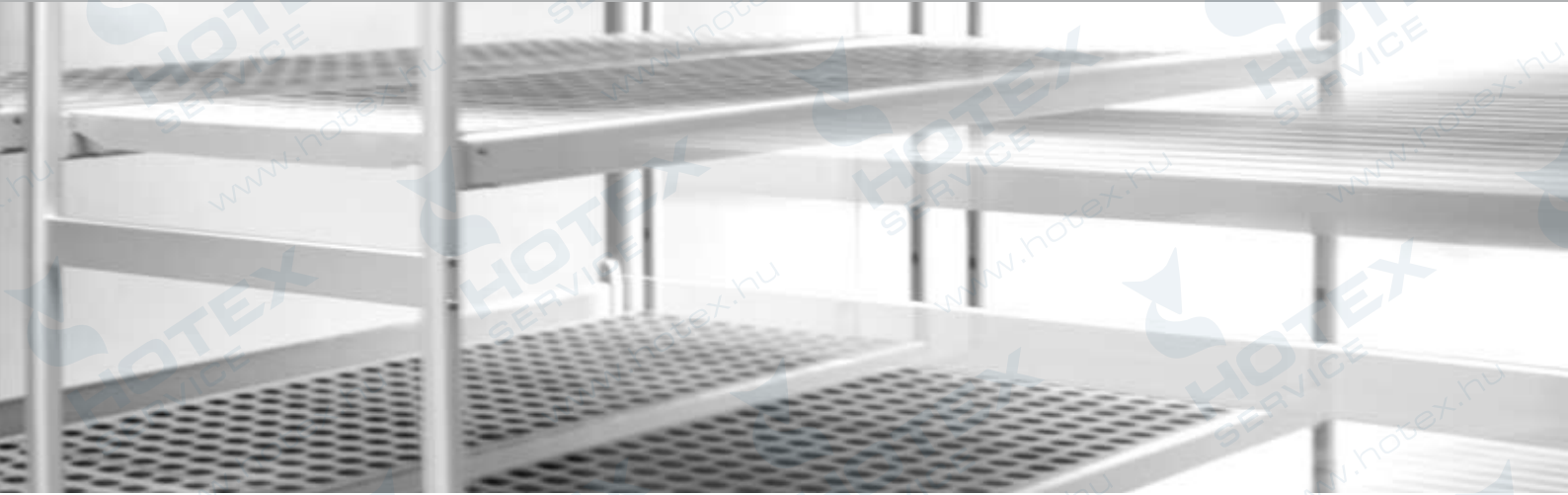

Scaffalature | Carrelli  
*Shelving | Trolleys*





**E'** da oltre 50 anni che la ITALMODULAR contribuisce con passione, tecnologia, qualità ed affidabilità ad organizzare e migliorare il modo di lavorare di uomini e aziende. Una realtà produttiva che si è sempre proposta come partner affidabile nel progettare soluzioni e sistemi modulari ad alto contenuto innovativo per razionalizzare ed organizzare gli spazi di stoccaggio all'interno di ogni ambiente lavorativo. L'esperienza maturata, i continui investimenti in tecnologia e risorse umane, il servizio di assistenza a livello internazionale, permettono oggi all'azienda di proporsi come valido punto di riferimento quando fattori come innovazione, qualità e servizio diventano indispensabili. Un complesso di grande efficienza che guida le sue esperienze verso soluzioni innovative a totale affidabilità in grado di rispondere, sempre e bene, alle più diversificate esigenze di ogni cliente.

**F**or over 50 years ITALMODULAR have been helping companies and their people organize and improve the way they work, with an injection of passion, technology, quality and reliability. This is a business that has unfailingly offered its services to customers as a reliable partner in designing highly innovative modular systems and solutions to rationalize and organize storage space within any workplace. Due to the experience gained, their continuous investments in technology and human resources and their international customer support service, the company now emerges as a solid benchmark wherever factors such as innovation, quality and service are of the essence. A highly efficient combination that steers Italmodular's efforts towards innovative and totally reliable solutions capable of consistently meeting and exceeding the many and varied demands of each customer.





Assemblaggio senza l'ausilio di attrezzi speciali  
*Assembly without need for special tools*



Veloce da assemblare  
*Quick to assemble*



Realizzato su progetto  
*Option of custom design*



Prodotto standard  
*Standard product*



Ripiani regolabili in altezza ogni 15 cm  
*Shelves height adjustable at 15 cm intervals*



Portata massima modulo scorrevole  
*Sliding module maximum load capacity*



Portata massima ripiano  
*Shelf maximum load capacity*



Griglie lavabili in lavastoviglie  
*Dishwasher-safe racks*



Adatto per ambienti refrigerati  
*Suitable for refrigerated rooms*



Alluminio anodizzato  
*Anodized aluminium*



Acciaio inox AISI 304  
*Aisi 304 stainless steel*



Garanzia  
*Warranty*



Facile e veloce pulizia dell'ambiente  
*Room quick and easy to clean*



Imballaggio termoretrato  
*Heat shrink wrapping*



Materiale riciclabile  
*Recyclable material*

# im|92

## Scaffalature | Carrelli

Scaffalature modulari e carrelli del sistema IM 92 rappresentano la soluzione ideale per chi deve organizzare, trasportare, esporre ed aumentare al meglio lo spazio di stoccaggio disponibile nel rispetto delle norme d'igiene. Le aree applicative del sistema IM 92 spaziano dal catering al settore alberghiero, dalle celle frigorifere a tutto il settore alimentare, dal farmaceutico ai magazzini in genere. Interamente realizzate in lega di alluminio anodizzato o in acciaio inox, garantiscono inalterabilità nel tempo contro la corrosione da acqua e umidità ed un elevato standard d'igiene. Stabili e solide non necessitano di fissaggi o ancoraggi particolari, sopportano alti carichi con il minimo di flessione. L'estrema semplicità e velocità di montaggio ottenuta grazie al sistema ad incastro brevettato dalla Italmobular permette un assemblaggio rapido e facile senza l'ausilio di attrezzi speciali. Il design elegante e l'ampia scelta di misure standard assicurano una grande adattabilità permettendo moltissime combinazioni con un notevole risparmio di spazio ed un ottimo rapporto qualità prezzo.

**pag. 6** | Scaffalatura aerea scorrevole

**pag. 12** | Scaffalatura modulare

**pag. 18** | Carrelli

## Shelving | Trolleys

*The modular shelving and trolleys making up the IM 92 system are the ideal solution for anyone needing to organize, handle, display and make the most of available storage space in compliance with hygiene standards. The IM 92 system lends itself to a host of different applications, ranging from catering to the hotel industry, from walk-in refrigerators to the whole food industry, from the pharmaceutical trade to storehouses in general. Made entirely from anodized aluminium alloy or stainless steel, they are guaranteed to offer lasting stability against corrosion by water and moisture and provide a high standard of hygiene. Both stable and sturdy, they do not need any special fastening or anchoring, while they are built to take heavy loads with minimal bending. The extreme simplicity and speed of assembly achieved thanks to the slot-together system patented by Italmobular mean assembly is quick and easy and can be performed without the aid of special tools. The elegant design and extensive choice of standard sizes make the shelving highly adaptable, allowing for a great many combinations and resulting in considerable space saving and an excellent quality/price ratio.*

**page 6** | Overhead sliding shelving

**page 12** | Modular shelving

**page 18** | Trolleys





im|92

NF



Scaffalatura aerea scorrevole  
*Overhead sliding shelving*



### **Ottimizzate più spazio.**

**La prima che sposta i limiti dello spazio disponibile.**

**Fino al 90% in più di superficie di stoccaggio nello stesso spazio.**

Questo nuovo modello di scaffalatura rappresenta la soluzione ottimale per organizzare ed aumentare lo spazio di stoccaggio disponibile. Il suo innovativo e brevettato sistema di scorrevolezza aereo, fluido e silenzioso, la rende la scelta ideale per poter aumentare dal 25% al 90% lo spazio di superficie di stoccaggio rispetto ad una scaffalatura tradizionale. Realizzata in lega di alluminio anodizzato con ripiani in polietilene o alluminio, questa versione di scaffalatura conferisce un maggior risparmio in termini di spazio utilizzabile, un maggior risparmio sull'installazione di impianti frigoriferi e di condizionamento con conseguente risparmio di energia elettrica e, grazie alla sua sospensione dal suolo, una più facile e veloce pulizia su tutto il pavimento, garantendo così maggiore igiene dell'ambiente. Il design moderno ed elegante, la sicura stabilità, la facilità di montaggio e l'elevata capacità di carico la rendono la soluzione ideale per chi deve organizzare ed aumentare al meglio lo spazio disponibile nelle molteplici esigenze applicative.



### **Optimize more space.**

**The first shelving to push the boundaries of available space.**

**Up to 90% more storage area packed into the same space.**

*This new shelving model is the optimal solution for organizing and increasing available storage space. Its innovative, patented overhead sliding system, which runs smoothly and quietly, makes it the ideal choice for increasing storage surface area by between 25% and 90% compared to traditional shelving. Made from anodized aluminium alloy with polyethylene or aluminium shelves, this shelving version rewards you with greater savings in terms of the amount of usable space; greater savings when it comes to installing cooling and air-conditioning systems, with the associated energy savings; and, because it is hung off the floor, the whole floor is easier and quicker to clean, thus resulting in a more hygienic space. The modern, elegant design, reliable stability, ease of assembly and the impressive load capacity make it the ideal solution for anyone needing to organize and make the most of available space, meeting the needs of numerous different applications.*





La prima scaffalatura scorrevole  
che può aumentare il vostro spazio di stoccaggio  
fino al 90% in più rispetto ad una scaffalatura fissa.

*The first sliding shelving capable of increasing  
your storage space by up to 90% more than fixed shelving.*

**Principali settori di applicazione**  
**Main fields of application**

Alimentare  
Food industry

Refrigerazione industriale  
Industrial refrigeration

Catering  
Catering

Alberghiero  
Hotel industry

Farmaceutico  
Pharmaceutical industry

Ospedaliero  
Hospitals

Arredo uffici  
Office furnishing

Magazzini  
Storehouses

**Un sistema per tutti gli usi realizzabile in qualsiasi misura.**

Il sistema per la sua grande versatilità aumenta ed organizza lo spazio in molteplici aree applicative e l'ampia scelta di misure standard assicura una grande adattabilità permettendo moltissime combinazioni con un notevole risparmio di spazio.

**A system that suits every purpose and can be tailored to size.**

With its great versatility, the system increases and organizes space in many areas of application, while the extensive choice of standard sizes makes the shelving highly adaptable, allowing for a great many combinations and resulting in considerable space saving.





**Esempio d'incremento di superficie di stoccaggio in cella da 10x5,7 m**  
**Example of increase in storage area in storage room measuring 10x5,7 m**

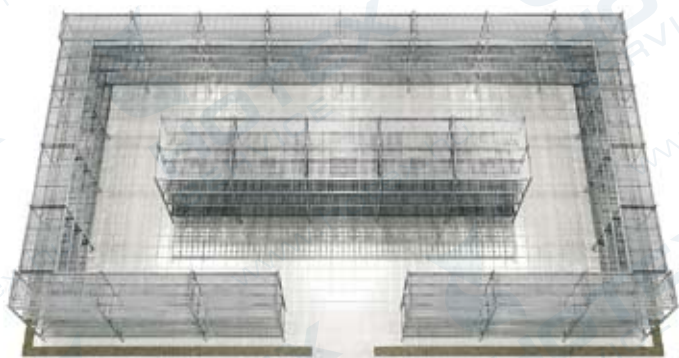

**Scaffalatura fissa.**  
**Modular shelving.**



**Scaffalatura aerea scorrevole.**  
**Overhead sliding shelving.**

**+90%**



**Massima stabilità ed elevata capacità di carico.**

Stabili e solide non necessitano di fissaggi o ancoraggi particolari, sopportano alti carichi con il minimo di flessione. Ogni modulo scorrevole ha una portata di circa 400 kg equivalenti a 1.600 Kg per un modulo standard.

**Unbeatable stability and high load capacity.**

*Both stable and sturdy, they do not need any special fastening or anchoring, while they are built to take heavy loads with minimal bending. Each sliding module has a load capacity of approx. 400 kg, which amounts to 1,600 kg for a standard module.*

**Facile e veloce da montare.**

L'estrema semplicità di montaggio ottenuta grazie al sistema ad incastro brevettato dalla Italmodular permette un assemblaggio semplice e veloce senza l'ausilio di attrezzi speciali.

**Quick and easy to assemble.**

*The extreme simplicity and speed of assembly achieved thanks to the slot-together system patented by Italmodular mean assembly is straightforward and fast and can be performed without the aid of special tools.*





La soluzione ottimale per organizzare  
ed aumentare lo spazio di stoccaggio disponibile

*Optimal solution for organizing and increasing  
available storage space*

**Un sistema di scorrevolezza fluido e silenzioso.**

Una qualità di scorrimento fluido con un movimento morbido e silenzioso.

**A smooth, quiet sliding system.**

*The greatest quality of the sliding system is its smooth, soft and quiet gliding.*

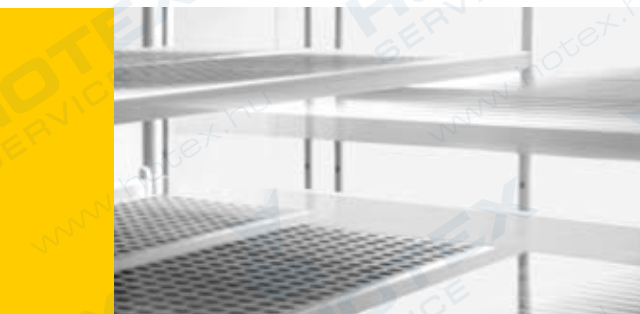

**Inalterabile nel tempo.**

Interamente realizzata in lega di alluminio anodizzato 12 e 20 micron con ripiani in polietilene o alluminio e materiali plastici atossici garantisce inalterabilità nel tempo contro la corrosione da acqua e umidità.

**Durable properties.**

*Made entirely from anodized aluminium alloy 12 and 20 microns thick, with shelves made from polyethylene or aluminium and non-toxic plastics, it is guaranteed to offer lasting stability against corrosion by water and moisture.*







### Elevato standard d'igiene.

Le superfici lisce ed arrotondate, i profili chiusi, la totale assenza di spazi e fessure dove possa annidarsi lo sporco e l'innovativa sospensione dal pavimento, che permette una più facile e veloce pulizia dell'ambiente, garantiscono un elevato standard di igiene.

### High standard of hygiene.

The smooth, rounded surfaces, the closed profiles, the total absence of gaps and cracks in which dirt can lurk and the innovative hanging system keeping the shelving off the floor - making the job of cleaning the space easier and quicker - combine to deliver a high standard of hygiene.

## Dati tecnici Technical specifications

(valori espressi in mm)  
(values given in mm)

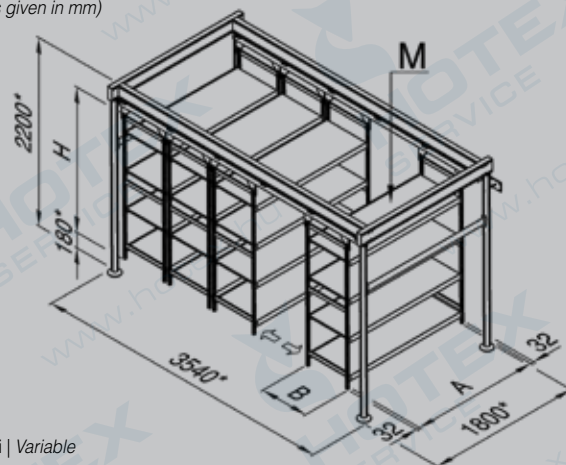

★: Variabili | Variable

### Configurazione base a 4 moduli Standard 4-module configuration

Modulo base scorrevole  
Standard sliding module

📦 (Kg)	A (mm)	B (mm)	H (mm)	N°
400	1505	557	1700	4

### Altre configurazioni possibili Other possible configurations

Modulo scorrevole  
Sliding module

A (mm)	📦 (Kg)	B (mm)	H (mm)	N°
532	400	557	1700	3 ÷ 13
620				
708				
798				
886				
974				
1062				
1152				
1240				
1330				
1505				

📦: Portata max | Max. load capacity

A: Lunghezza ripiano | Shelf length

B: Larghezza | Width

H: Altezza | Height

N°: Numero max ripiani | Max. number of shelves

M: Modulo scorrevole | Sliding module

### Optional Optional

Barra anticaduta.  
Retaining bar.

Separatore.  
Separator.

Segnalatore.  
Label.





# im|92



## Scaffalatura modulare *Modular shelving*





### Organizza lo spazio come preferisci.

Questo sistema di scaffalatura, per la sua grande versatilità, organizza e ottimizza lo spazio in ogni ambiente. Realizzata in lega di alluminio anodizzato con ripiani in alluminio o polietilene o in acciaio inox AISI 304, garantisce inalterabilità nel tempo contro la corrosione da acqua e umidità ed un elevato standard d'igiene. La qualità della scaffalatura modulare IM 92 è infatti garantita dai marchi internazionali NF ed NSF. Design elegante, alta capacità di carico, massima stabilità, facilità e velocità di montaggio sono alcune delle peculiarità di questa scaffalatura che insieme all'ampia scelta di misure standard assicurano una grande adattabilità consentendo moltissime combinazioni con un notevole risparmio di spazio in molteplici necessità applicative. Inoltre, grazie allo "Shelving Optimization", un software facile da utilizzare che la Italmodular rilascia ai propri rivenditori, è possibile in pochi minuti scegliere la soluzione di arredo più adatta all'applicazione desiderata con la visualizzazione 3D della soluzione e il relativo preventivo, senza più dover perdere tempo con tabelle od inutili calcoli manuali.



### Organize space as it best suits you.

The great versatility of this shelving system means you can organize and optimize space in any room. Made from anodized aluminium alloy with aluminium or polyethylene shelves or AISI 304 stainless steel, it is guaranteed to offer lasting stability against corrosion by water and moisture and provide a high standard of hygiene. In point of fact, the quality of the IM 92 modular shelving is guaranteed by the international marks NF and NSF. An elegant design, high load capacity, unbeatable stability and ease and speed of assembly are some of the features that - together with the extensive choice of standard sizes - make this shelving highly adaptable, allowing for a great many combinations and resulting in considerable space saving, meeting the needs of numerous different applications. Moreover, with the aid of "Shelving Optimization" - an easy-to-use software that Italmodular issues to their dealers - it takes just a few minutes to choose the furnishing solution that best suits the desired application by viewing the solution in 3D along with the relevant estimate: all the hassle of consulting tables and doing time-consuming calculations by hand is now a thing of the past.





La soluzione ideale per razionalizzare  
ed organizzare lo spazio di stoccaggio disponibile

*Optimal solution for rationalizing  
and organizing available storage space*

**Principali settori di applicazione**  
**Main fields of application**

Alimentare  
*Food industry*

Refrigerazione industriale  
*Industrial refrigeration*

Catering  
*Catering*

Alberghiero  
*Hotel industry*

Farmaceutico  
*Pharmaceutical industry*

Ospedaliero  
*Hospitals*

Arredo uffici  
*Office furnishing*

Magazzini  
*Storehouses*

**Un sistema personalizzabile in qualsiasi misura.**

Il sistema per la sua grande versatilità organizza e ottimizza lo spazio in molteplici aree applicative e l'ampia scelta di misure standard assicurano una grande adattabilità permettendo moltissime combinazioni con un notevole risparmio di spazio.

**A system that can be tailored to any size.**

With its great versatility, the system organizes and optimizes space in many areas of application, while the extensive choice of standard sizes makes the shelving highly adaptable, allowing for a great many combinations and resulting in considerable space saving.







### **Garantita nel tempo.**

Interamente realizzata in lega di alluminio anodizzato 20 micron con ripiani in alluminio o polietilene e nella versione in acciaio inox AISI 304, garantisce inalterabilità nel tempo contro la corrosione da acqua e umidità.

### **Guaranteed to last.**

Made entirely from anodized aluminium alloy 20 microns thick with shelves made from aluminium or polyethylene, and in the AISI 304 stainless steel version, it is guaranteed to offer lasting stability against corrosion by water and moisture.



### **Grande stabilità ed alta capacità di carico.**

Stabili e solide non necessitano di fissaggi o ancoraggi particolari, sopportano alti carichi con il minimo di flessione. Un ripiano di cm 100 ha una portata di circa 200 kg.

### **Impressive stability and high load capacity.**

Both stable and sturdy, they do not need any special fastening or anchoring, while they are built to take heavy loads with minimal bending. A 100cm shelf has a load capacity of approx. 200 kg.





Scaffalatura in acciaio inox | Stainless steel shelf

### Standard d'igiene elevato.

Le superfici lisce ed arrotondate, i profili chiusi, la totale assenza di spazi e fessure dove possa annidarsi lo sporco garantiscono un elevato standard di igiene.

### High standard of hygiene.

The smooth, rounded surfaces, the closed profiles and the total absence of gaps and cracks in which dirt can lurk combine to deliver a high standard of hygiene.

Alluminio | Aluminum

Polietilene | Polyethylene



Gastronorm



### Ripiani intercambiabili

Forniti nelle tre versioni in alluminio anodizzato 20 micron, polietilene e acciaio inox AISI 304 si distinguono per la facile estraibilità, il design elegante e moderno e per la facilità di pulizia che ne garantisce una perfetta igiene. Inoltre nelle larghezze 373 mm e 577 mm i pianetti e le griglie sono sostituibili con le bacinelle gastronorm.

### Interchangeable shelves.

Shelves come in three versions - anodized aluminium 20 microns thick, polyethylene and AISI 304 stainless steel - and have a number of distinguishing traits: they are easy to remove, boast an elegant, modern design and are easy to clean, making them thoroughly hygienic. Moreover, with the 373mm and 577mm wide versions, you have the option of replacing solid shelves and racks with Gastronorm containers.







### Il software per il calcolo automatico della composizione.

Facile e veloce da utilizzare permette di comporre e visualizzare in 3D la soluzione con il relativo preventivo.

### Automatic composition calculation software.

Quick and easy to use, it enables you to put the composition together and gives a 3D view of the solution along with the relevant estimate.

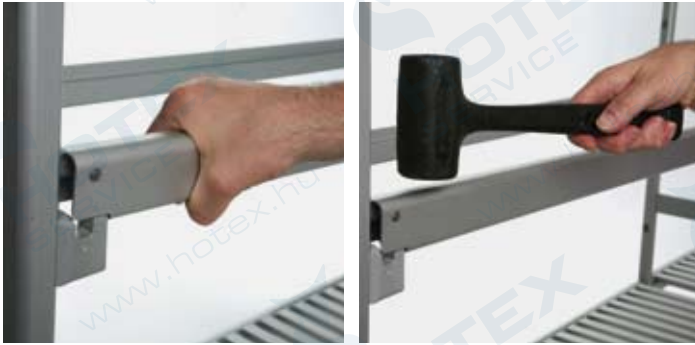

### Semplice e veloce da montare.

L'estrema semplicità di montaggio ottenuta grazie al sistema ad incastro brevettato dalla Italmodular permette un assemblaggio semplice e veloce senza l'ausilio di attrezzi speciali.

### Quick and simple to assemble.

The extreme simplicity and speed of assembly achieved thanks to the slot-together system patented by Italmodular mean assembly is straightforward and fast and can be performed without the aid of special tools.



## Dati tecnici Technical specifications

(valori espressi in mm)  
(values given in mm)

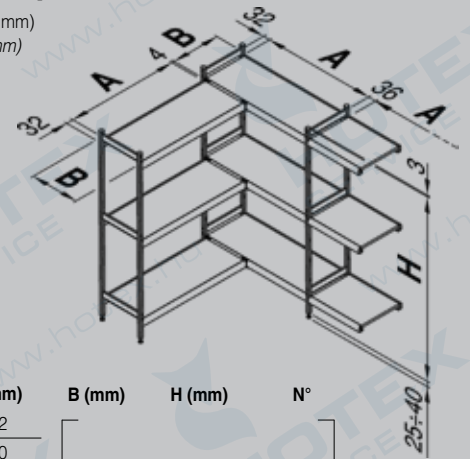

📦 (Kg)	A (mm)	B (mm)	H (mm)	N°
260	532			
250	620			
240	708			
230	798			
220	886			
210	974			
190	1062	373	1550	
170	1152	475	1700	3 ÷ 13
150	1240	577	2000	
140	1330			
120	1505			
110	1682			
100	1770			
90	1858			
80	1946			

📦: Portata ripiano lineare | Linear shelf load capacity

A: Lunghezza ripiano | Shelf length

B: Larghezza | Width

H: Altezza | Height

N°: Numero max ripiani | Max. number of shelves

### Optional Optional

Ruota girevole con e senza freno ø 100 mm.  
Locking and non-locking swivel castor ø 100 mm.



Barra in acciaio inox ø 15 mm per appendere salumi.  
Stainless steel bar ø 15 mm for hanging cold meats.



Barra anticaduta.  
Retaining bar.



Separatore.  
Separator.

Segnalatore.  
Label.



# im|92



## Carrelli *Trolleys*



## CARRELLO ESPOSITORE.

### La soluzione espositiva funzionale e versatile.

Un carrello destinato all'esposizione e allo stoccaggio di ogni genere di prodotto. Un sistema pratico ed elegante che permette di esporre al meglio cassette di frutta e verdura, bottiglie di vino, ceste per il pane, vaschette di fiori etc. Realizzato nella versione in alluminio anodizzato e disponibile a scelta con ripiani in alluminio o polietilene si caratterizza per le sue qualità di robustezza, stabilità, praticità e durabilità nel tempo. Equipaggiato con 4 ruote pivotanti in acciaio zincato dotate di fermo, lo rendono particolarmente sicuro e facilmente manovrabile anche durante il trasporto a pieno carico. Facile e veloce nel montaggio può essere fornito in una vasta gamma di misure e adattabile ad ogni soluzione espositiva.

## CARRELLO MODULARE.

### Il trasporto stabile e pratico.

Questo carrello è stato ideato e realizzato per il trasporto di ogni genere di prodotto alimentare e non dalla zona di scarico al magazzino.

Realizzato nella versione in alluminio anodizzato idoneo al contatto con alimenti si distingue per le sue eccellenti doti di robustezza, stabilità e praticità.

Le ruote pivotanti in acciaio zincato dotate di fermo, lo rendono particolarmente sicuro e facilmente manovrabile anche a pieno carico. Design elegante, silenzioso e disponibile in un'ampia scelta di misure standard e con ripiani in alluminio anodizzato 20 micron o polietilene, rappresenta la soluzione ottimale in molteplici esigenze applicative.



## DISPLAY TROLLEY.

### Functional and versatile display solution.

A trolley designed to display and store all manner of products. A practical, elegant system for putting crates of fruit and vegetables, wine bottles, bread baskets, trays of flowers etc. on best display. It comes in anodized aluminium with a choice of aluminium or polyethylene shelves and is characterized by its strength, stability, practicality and lasting durability. It features 4 galvanized steel locking swivel castors, which make it particularly safe and easy to handle even when carrying a full load. Quick and easy to assemble, it can be supplied in a wide range of sizes and can adapt to cater to any display need.

## MODULAR TROLLEY.

### Stable, practical handling.

This trolley has been designed and manufactured to carry all manner of foodstuffs and other products from the unloading area to the storeroom. It comes in food-safe anodized aluminium and stands out for its excellent strength, stability and practicality. The galvanized steel locking swivel castors make it particularly safe and easy to handle even when carrying a full load. With an elegant design and quiet operation, it comes in an extensive range of standard sizes and has shelves made from anodized aluminium 20 microns thick or polyethylene, making this the optimal solution to meet the needs of numerous applications.







La soluzione ottimale per trasportare, esporre, stivare.

*Optimal solution for handling, displaying, storing.*

**Robusto e stabile.**

Sopporta alti carichi con il minimo di flessione.  
Un ripiano di 1152 mm ha una portata di 110 kg.

**Strong and stable.**

*Built to take heavy loads with minimal bending.  
A 1152 mm shelf has a 110 kg load capacity.*

**Principali settori di applicazione**  
**Main fields of application**

Alimentare  
Food industry

Refrigerazione industriale  
Industrial refrigeration

Catering  
Catering

Alberghiero  
Hotel industry



**Adattabile ad ogni soluzione espositiva.**

Un sistema pratico ed elegante in una vasta gamma di misure disponibili che permette di risparmiare spazio ed esporre al meglio cassette di frutta e verdura, bottiglie di vino, ceste per il pane, vaschette di fiori e tante altre soluzioni espositive.

**Adapts to meet any display need.**

*A practical, elegant system in a wide range of available sizes for saving space and putting crates of fruit and vegetables, wine bottles, bread baskets and trays of flowers on best display, while it lends itself to many other display solutions.*





### Ripiani intercambiabili idonei al contatto con alimenti.

Forniti nelle due versioni in alluminio anodizzato 20 micron e polietilene si distinguono per la facile estraibilità, per il design elegante e moderno e per la loro facilità di pulizia che ne garantisce una perfetta igiene garantendo l'idoneità al contatto con alimenti.

### Food-safe interchangeable shelves.

Shelves come in two versions - anodized aluminium 20 microns thick and polyethylene - and have a number of distinguishing traits: they are easy to remove, boast an elegant, modern design and are easy to clean, making them thoroughly hygienic and thus food safe.



### Silenzioso, sicuro e facilmente manovrabile anche a pieno carico.

Le ruote pivotanti in acciaio zincato dotate di fermo lo rendono particolarmente sicuro, facilmente manovrabile e silenzioso anche durante il trasporto a pieno carico.

### Quiet, safe and easy to handle even when carrying a full load.

The galvanized steel locking swivel castors make it particularly safe, easy to handle and quiet even when carrying a full load.



## Dati tecnici Technical specifications

(valori espressi in mm)  
(values given in mm)

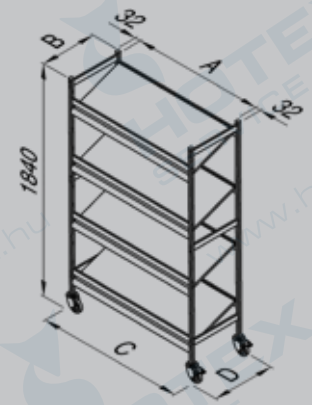

### Carrello espositore Display trolley

📦 (Kg)	A (mm)	C (mm)	B (mm)	D (mm)	N°
160	798	907			
140	886	995			
130	974	1083			
120	1062	1171			
110	1152	1261	450	500	3 ÷ 5
100	1240	1349	560	600	
90	1330	1439			
80	1505	1614			

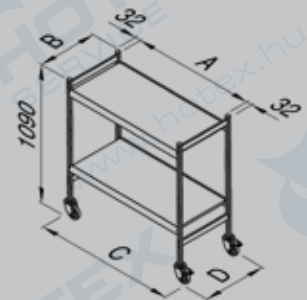

### Carrello modulare Modular trolley

📦 (Kg)	A (mm)	C (mm)	B (mm)	D (mm)	N°
180	708	817			
160	798	907			
140	886	995	373	418	2 ÷ 6
130	974	1083	475	520	
120	1062	1171	577	622	
110	1152	1263			

- 📦: Portata ripiano | Shelf load capacity
- A: Lunghezza ripiano | Shelf length
- B: Larghezza | Width
- C: Ingombro | Overall length
- D: Ingombro | Overall width
- N°: Numero max ripiani | Max. number of shelves

### Optional Optional

Barra anticaduta.  
Retaining bar.

Separatore.  
Separator.

Segnalatore.  
Label.



## Certificazioni | Certifications



**Marchio NF Igiene Alimentare Assegnato da:**

**AFAQ-AFNOR CERTIFICATION**

11, Av. Francis de Pressensè

93571 Saint-Denis la Plaine Cedex - F -

Questo marchio certifica la conformità secondo il riferimento NF 031

Caratteristiche certificate:

- Attitudine alla pulizia

**NF Food Hygiene Label assigned by:**

**AFAQ-AFNOR CERTIFICATION**

11, Av. Francis de Pressensè

93571 Saint-Denis la Plaine Cedex - F -

*This label certifies that the product is manufactured in accordance with norm NF 031*

*It certifies that:*

- *The product is suitable in terms of hygiene*

### Imballaggio

Per garantire al meglio la protezione dei prodotti ed ottimizzare lo spazio durante la spedizione e l'immagazzinaggio le testate e i ripiani del sistema IM92 vengono imballate separatamente con protezioni in cartone e sigillati in uno strato di plastica termoretratta. Una garanzia in più per l'integrità del prodotto.

### Packaging

*To ensure products get the best possible protection and to optimize space during shipment and storage, the sides and shelves of the IM92 system are packed separately with cardboard protectors and shrink-wrapped. Extra assurance that the product will arrive undamaged.*



**Assegnato da NSF**

**INTERNATIONAL P.O. BOX 130140**

**ANN ARBOR MICHIGAN 48113 0140 U.S.A.**

Questo marchio certifica la conformità secondo gli standard NSF ANSI & RCV 02

Caratteristiche certificate:

- Attitudine alla pulizia
- Attitudine al funzionamento
- Valutazione tossicologica e verifica dell'idoneità dei materiali
- Verifica annuale dei prodotti certificati
- Contatto diretto con gli alimenti nella versione griglie in alluminio

**Assigned by NSF INTERNATIONAL P.O. BOX**

**130140ANN ARBOR MICHIGAN 48113 0140**

**U.S.A.**

*This label certifies that the product is manufactured in accordance with NSF ANSI & RVC 02 norms.*

*It certifies that:*

- *The product is suitable in terms of hygiene*
- *The product is suitable for the uses stated*
- *The materials used in manufacture are non-toxic and suitable for use in food handling and storage*
- *The product is checked every year to ensure it continues to meet the above norms*
- *Direct food contact with aluminium grids*



## Garanzia | Warranty

---

La garanzia si limita ai componenti che presentano difetti di fabbricazione e contro la corrosione da acqua e umidità. La garanzia non avrà valore per danni causati da un uso improprio e/o negligenza dell'utilizzatore, da eventuali sovraccarichi di peso, da agenti atmosferici, dall'uso di prodotti chimici, acidi e sale. La garanzia non comprende il trasporto dei componenti di ricambio e la mano d'opera di eventuale tecnico.

*Warranty coverage is limited to parts showing defects in materials and workmanship or affected by corrosion by water and moisture. The warranty shall not be valid for damage caused by improper use and/or carelessness by the user, by overloading, by atmospheric agents, by the use of chemicals, acids and salt. The warranty does not include the shipping of spare parts and the labour of technical personnel whose work may be required.*



26025 Pandino (CR) Italy  
Via De Gasperi, 25  
Tel. +39 0373 970296 / 970184  
Fax +39 0373 970329  
[www.italmodular.com](http://www.italmodular.com)  
[info@italmodular.com](mailto:info@italmodular.com)

Rivenditore autorizzato:  
Authorized dealer:

---